

All the facts at a glance

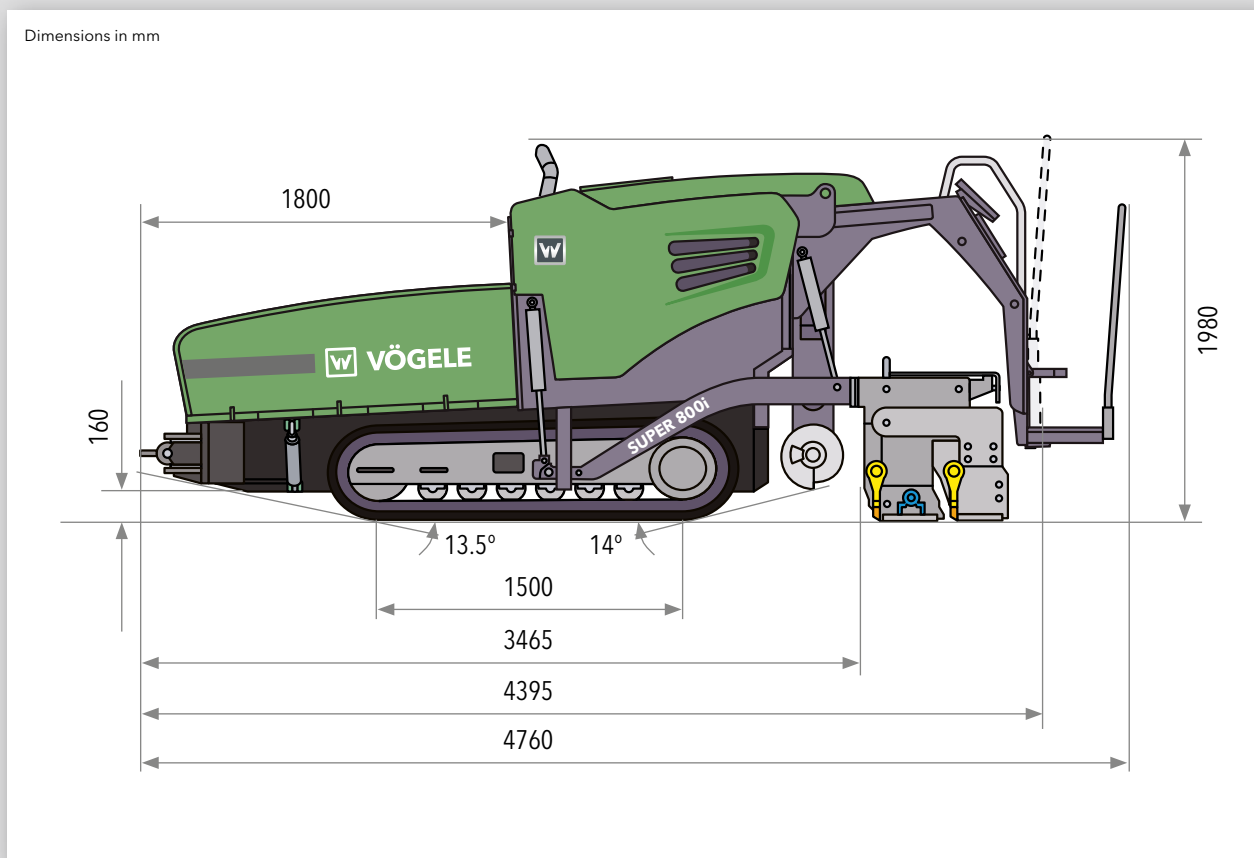

Power unit	
Engine	4-cylinder diesel engine, liquid-cooled
Manufacturer	Deutz
Type	TCD 2.9 L4
Output	
Nominal	55.4kW at 2,200rpm (according to DIN)
ECO mode	54kW at 1,800rpm
Exhaust emissions standard	EU Stage 4, US EPA Tier 4f
Exhaust gas after-treatment	DOC
Emission data	
Sound power level	≤104 dB(A) (2000/14/EC and DIN EN 500-6)
Daily noise exposure level	>80 dB(A) (DIN EN 500-6)
Fuel tank	80 litres

Undercarriage	
Crawler tracks	provided with rubber pads
Ground contact	1,500mm x 180mm
Suspension	rigid
Track tension adjuster	spring assembly
Track roller lubrication	lifetime
Traction drive	separate hydraulic drive and electronic control provided for each crawler track
Speeds	
Paving	up to 30m/min., infinitely variable
Travel	up to 3.6km/h, infinitely variable
Service brake	hydraulic
Parking brake	spring-loaded multiple-disc brake, maintenance-free

Material hopper	
Hopper capacity	5.8t
Width	2,900mm
Feed height	500mm (bottom of material hopper)
Push-rollers	oscillating, fold up with the sides of the material hopper, adjustable by 100mm to the front, 50cm to the left

Key: **DOC** = Diesel Oxidation Catalyst **AB** = Extending Screed **TV** = with tamper and vibrators

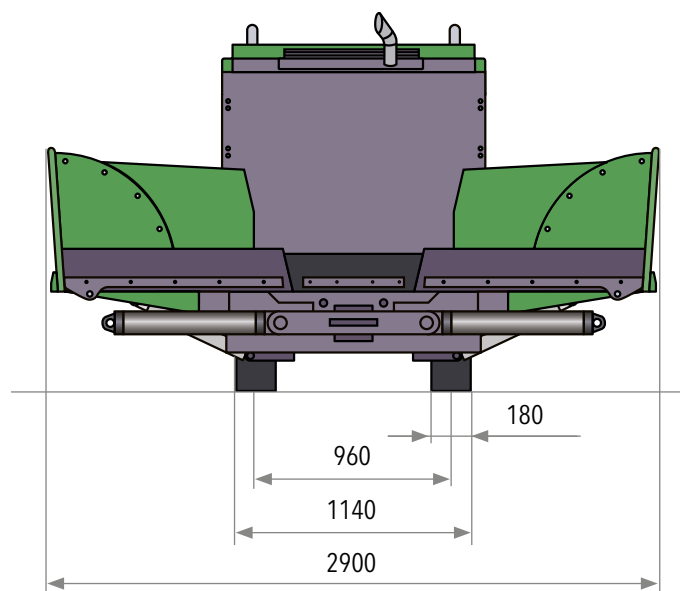

Conveyor and augers	
Conveyor	1, with replaceable feeder bars, conveyor movement is reversible
Drive	hydraulic
Speed	up to 20m/min., infinitely variable (manual or automatic)
Augers	2, mounted overhung, auger rotation is reversible
Diameter	300mm
Drive	separate hydraulic drive provided for each auger
Height	
Standard	infinitely variable by 10cm, mechanical
Option	infinitely variable by 10cm, hydraulic

Screed	
AB 220	basic width 1.2m infinitely variable range 1.2m to 2.2m maximum width 3.5m minimum pave width with system for pave width reduction 0.5m
Screed version	TV
Layer thickness	up to 20cm
Screed heating	electric by heating rods
Power supply	three-phase A.C. generator
Dimensions (transport) and weight	
Clearance width	1.4m
Length	tractor unit and screed
AB 220 TV	4.4m
Weight	tractor unit and screed
AB 220 TV	6,600kg

Subject to technical alterations.